

Technique

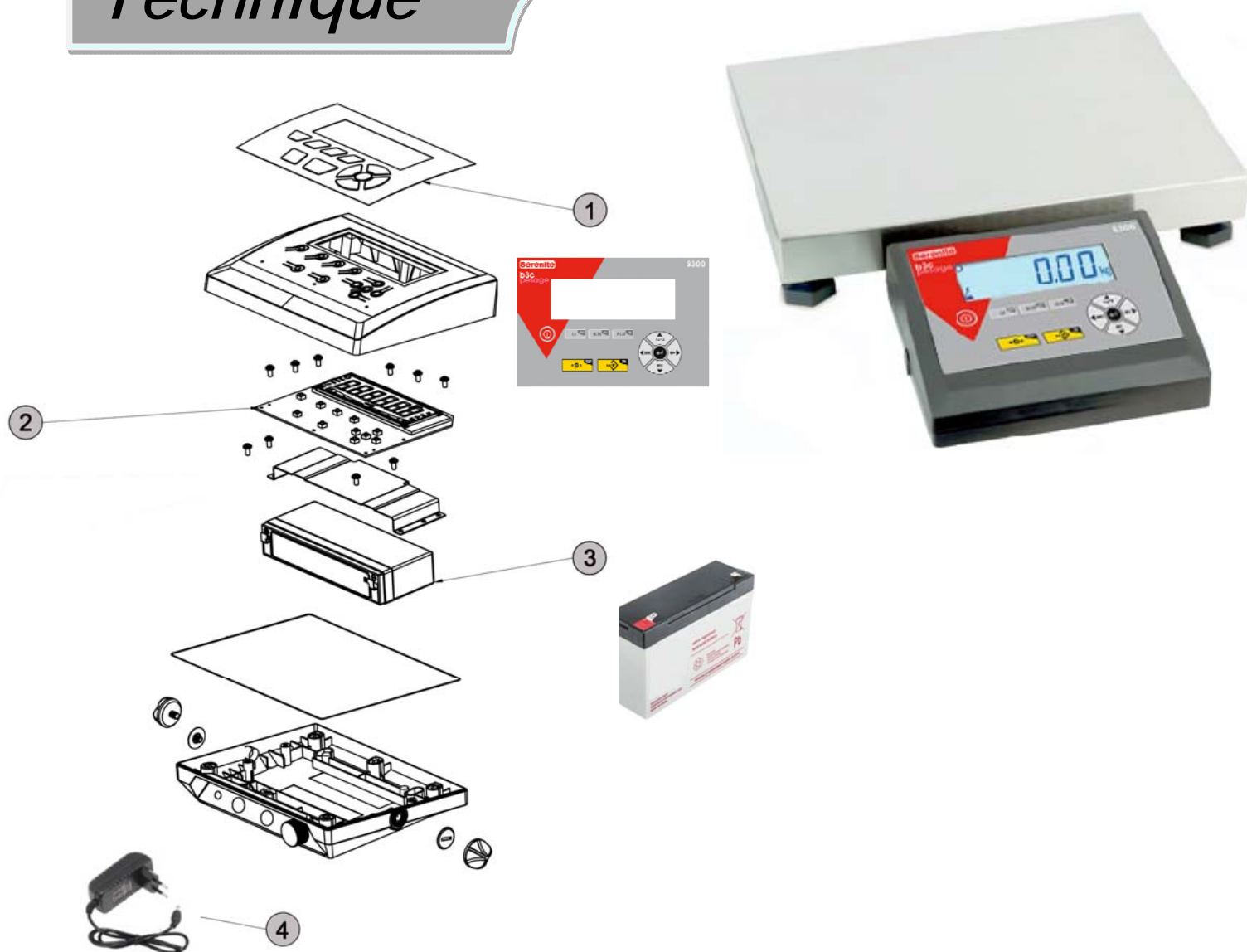

N°	Désignations	Références
1	Face avant / Front overlay S300	33012
2	Carte principale CPU / CPU Complete mainboard S300	721
3	Batterie / Battery <i>6V5.0 AH / 20HR</i>	32276
4	Bloc d'alimentation / Power supply <i>100-240VAC 50/60HZ output 12V DC 800mA</i>	32303
	Bloc d'alimentation UK / UK Power supply <i>100-240VAC 50/60HZ output 12V DC 800mA</i>	32303-UK



CABLAGE

- 1 Blanc
- 2 Vert
- 3 Noir
- 6 Rouge

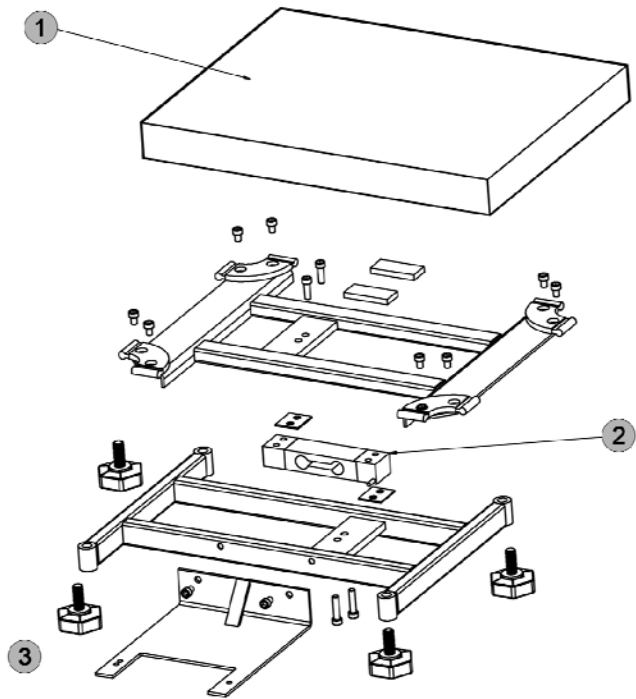

N°	Modèles	Désignations	Références
1	S300-30 S300-60	Plateau inox / Stainless steel pan <i>400x300 AISI304</i>	P201-3040
	S300-60-XL S300-150-XL	Plateau inox / Stainless steel pan <i>500x400 AISI304</i>	P201-4050F2
2	S300-30 <i>400 x 300</i>	Capteur / Load cell – 30kg/10g	1060323
	S300-60 <i>400 x 300</i>	Capteur / Load cell – 60kg/20g	1060294
	S300-60-XL <i>500 x 400</i>	Capteur / Load cell – 60kg/20g	31826
	S300-150-XL <i>500 x 400</i>	Capteur / Load cell – 150kg/50g	1060550
3		Pied réglable / Leveling feet	30841
4		Fiche Din 7 / 7 poles plug DIN	BR-310



10 Boulevard des Alliés
91720 MAISSE – France
Tel : (+33) 01 64 99 34 34 - Fax (+33) 01 64 99 33 55
Mail : b3c@orange.fr
Web : www.b3c-pesage.fr